

## W3

### Safety

**! WARNING**

This product contains high intensity LED devices. To prevent eye damage, do not look into the light beam at close range.

### Technical Data

Attribute	Units
Lens	Polycarbonate
Color, lens	Clear or blue
Color, LED, End modules	Blue, amber, red or blue/amber
Color, LED, Inboard modules	Blue/amber, blue/red. Blue/white, white/amber, blue/green, red/empty, white/empty, empty/amber, blue/empty or red/amber
Cable	4.5 m
Voltage	12- 24 V DC
Power consumption	20 A with peak at 30 A for less than 50 ms
Length	930, 1100, 1270, 1440, 1600, 1770 or 1940 mm
Height	Corner module: 65 mm Inboard module: 47 mm
Width	280 mm
Interface	CAN bus of a Standby Control System or break out box
Operating temperature	-40°C – +85°C
Approvals	ECE R6, ECE R7, ECE R10, ECE R65, ICAO

### Parts Overview

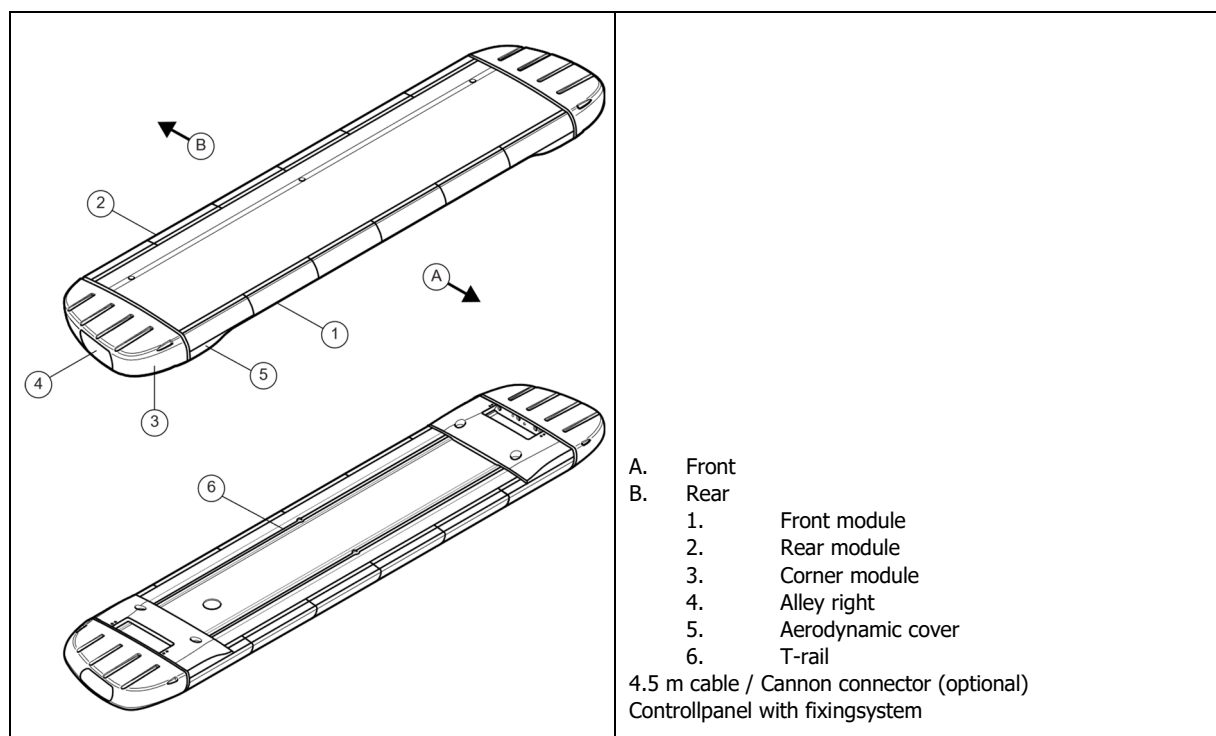

Dimensions

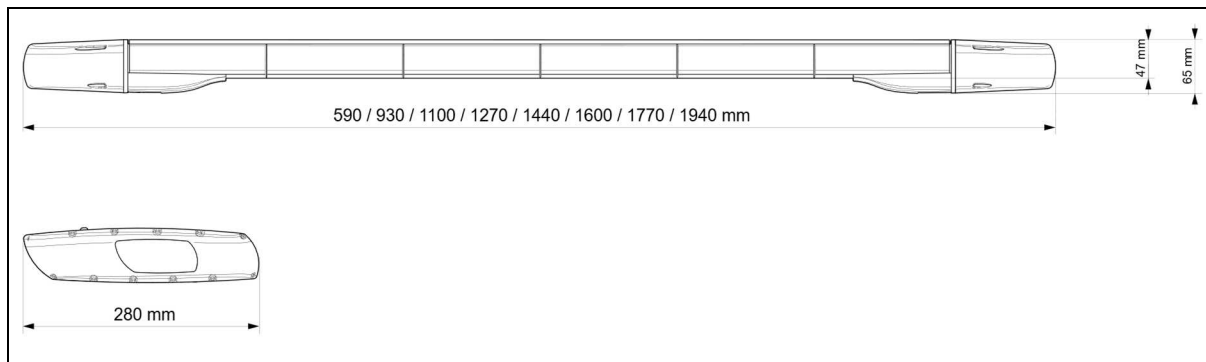

Break out box connection to W3 Lightbar

Color examples:

- Blue/Amber Lightbar, Blue=1 Amber=2
- Red/Amber Lightbar, Red= 1 Amber =2

**! Note**

Input X18 is only used during configuration and should always be set back to 0 when configuration is done.

Function	Input	Additional input	Cable color
Day/Night (night mode when active)	X01	X18=0	Blue/White
Reset changeable functions to default	X18=1		
360° Color 1 Front Corner light	X02		Green/White
360° Color 1 Rear Corner light	X03		Grey
Front Color 1 Emergency light (inboard modules)	X04		Black
Rear Color 1 Emergency light (inboard modules)	X05		Light Green
360° Color 2 Corner light	X06		Brown/White
Front Color 2 Warning light	X07		Purple
Rear Color 2 Warning light	X08	X18=0	White
Change behavior if color 1&2 are activated at the same time. Mode 0-1-2	X18=1		
Turn Signal Left	X09		Black/White
Turn Signal Right	X10		Grey/White
Running light Left	X11	X22=1	Purple/White(X11)
Brake light	X22=0		
Running light Right	X12	X22=1	Pink/White (X12)
Position light	X22=0		
Green Warning light (Front & Rear) /Police Stop inc Takedown	X13	X18=0	Blue
Change function on X13 between Green(default) & Police	X18=1		
Take Down (White Front Light)	X14		Green
Alley light Left	X15		Yellow
Alley light Right	X16		Orange
Work light Rear	X17		Red
Enable Config mode	X18		Pink
Airport Mode (ICAO) ***	X19		Red/White
Red Warning light (Front & Rear)	X20	X18=0	Brown
Special vehicle configuration (on negative edge): Police SE	X18=1		
Running light Center	X21	X22=1	Yellow/White (X21)
Enable Running light	X22		Orange/White
Flash Configuration (on negative edge) mode 0-1-2-3-4-5	X23	X18=1	Red/Black (X23)
Warning Light (running light)	X22=1 & X18=0		
Flash Pattern select (on negative edge) Triple-Double-Single-Custom-ICAO	X24	X18=1	Light Green/White (X24)
Cruise Light (on selected modules)	X18=0		

Connections

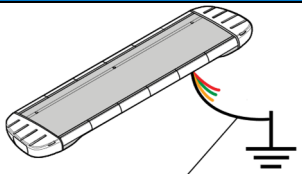
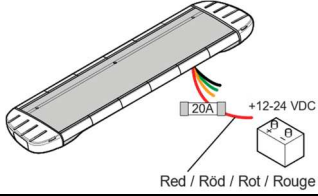
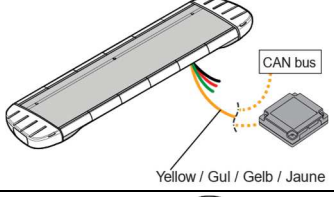
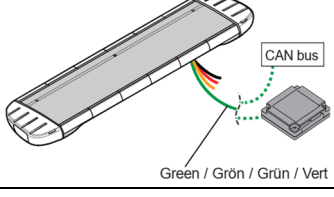
Wire	Functions	Connect to	
<b>Black</b>	Power supply	Good and suitable ground	 <p>Black / Svart / Schwarz / Noir</p>
<b>Red</b>	Power supply	12-24 V DC via a 20 A fuse	 <p>Red / Röd / Rot / Rouge</p>
<b>Yellow</b>	CAN	CAN bus of a Standby Control System or break out box	 <p>Yellow / Gul / Gelb / Jaune</p>
<b>Green</b>	CAN	CAN bus of a Standby Control System or break out box	 <p>Green / Grön / Grün / Vert</p>

Installation

**Table 1. Installation – General recommendations**

1. Use fixing screws, by hand, to attach the roof brackets on the t-rails of the lightbar bottom. Do not tighten.

2. Pre install lightbar with the brackets on the vehicle roof rails. The Standby label is placed on the lightbar FRONT part.

3. Align the lightbar with the B-pillar.

4. Cabling preparations:  
 1. Mark a suitable location for the lightbar cables access hole.  
 2. Pre drill its center.

5. Pre install the lightbar and brackets on the vehicle roof rails. Make sure that the lightbar top line is horizontal.

6. Adjust and tighten the fixing screws (brackets and lightbar).

7. Feed the lightbar cables through the vehicle roof.

8. Fasten the lightbar top and mount the aerodynamic covers.

**Table 2. Installation – Cannon connector as an option**

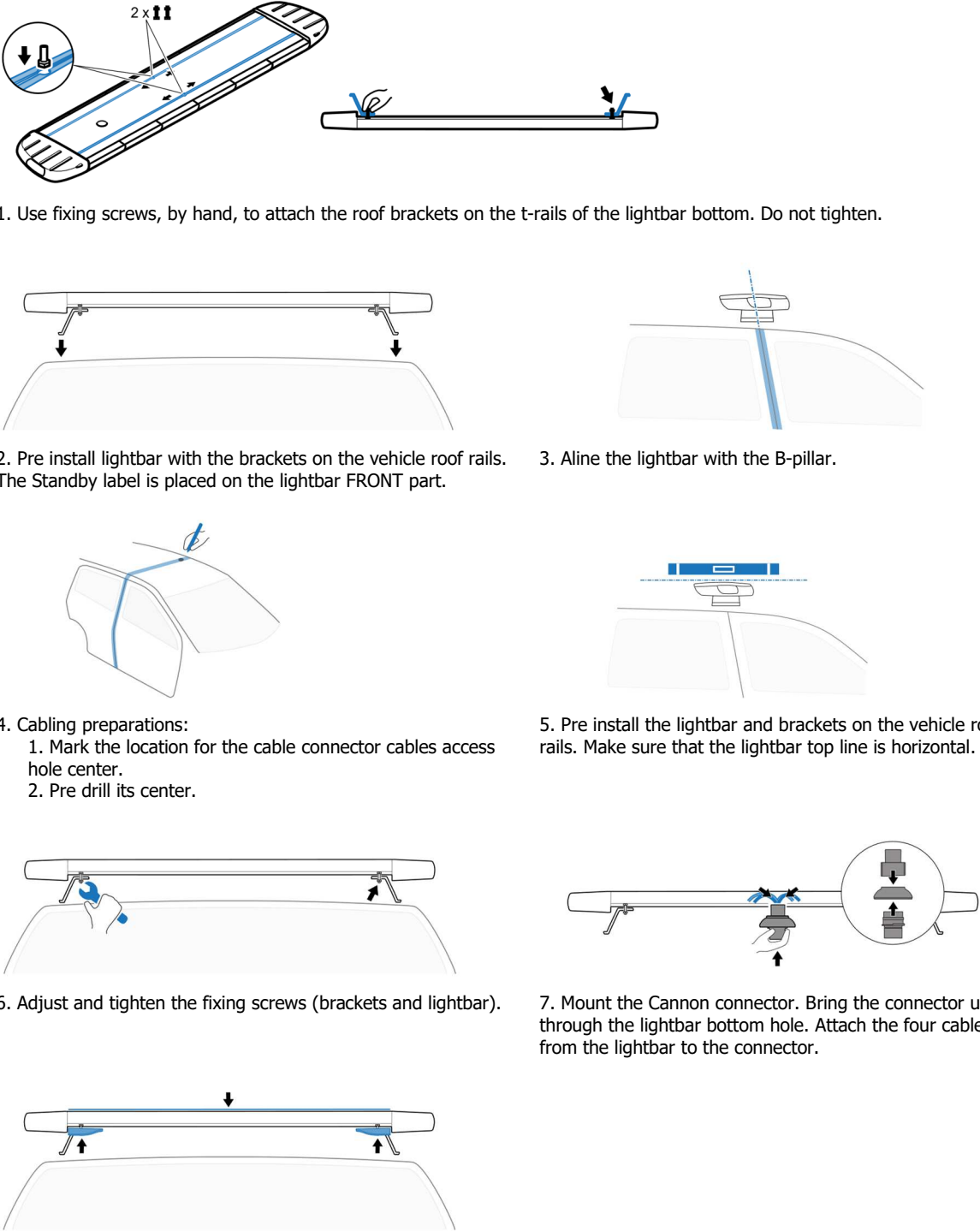

1. Use fixing screws, by hand, to attach the roof brackets on the t-rails of the lightbar bottom. Do not tighten.

2. Pre install lightbar with the brackets on the vehicle roof rails. The Standby label is placed on the lightbar FRONT part.

3. Align the lightbar with the B-pillar.

4. Cabling preparations:  
 1. Mark the location for the cable connector cables access hole center.  
 2. Pre drill its center.

5. Pre install the lightbar and brackets on the vehicle roof rails. Make sure that the lightbar top line is horizontal.

6. Adjust and tighten the fixing screws (brackets and lightbar).

7. Mount the Cannon connector. Bring the connector up through the lightbar bottom hole. Attach the four cables from the lightbar to the connector.

8. Fasten the lightbar top and mount the aerodynamic covers.

## Maintenance

**! Note**

Use a mild car wash shampoo and a sponge that is gentle/appropriate to the lightbar surface as well as the vehicle surface.

**! CAUTION**

When using high-pressure cleaner:

Water pressure at a maximum of 80 bar.

Minimum distance of 80 cm between the gun and the lightbar.

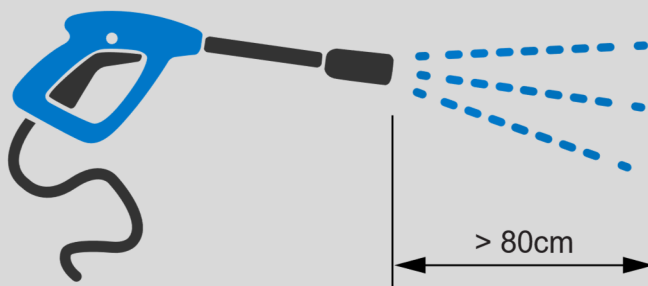

Direct the gun so that the spray pattern hits the surface at a 90° angle.

Always thoroughly rinse with clean water after a high-pressure wash.

Follow the steps above to avoid negative impacts on packing seal, logos and decals.

**! Caution**

Do not use degreaser.

**! Caution**

Machine wash with brushes is acceptable, as long as the brushes are clean. However this will increase the risk of the plastic becoming matte and scratchy.