

TRIPOD MOBILITY WHEELCHAIR ACCESSIBLE VEHICLES



VOLKSWAGEN

Caddy 5

Caddy Maxi 5



COMFORTABLE, LUXURIOUS AND SPACIOUS

Most popular model for conversion to Wheelchair Accessible Vehicle (WAV).
Both Caddy and Caddy Maxi available with up to 7 seats.

BROCHURE

L1

Caddy 5 is the short version.
Carlength 4,50m.

Tested and approved by:



Measurements

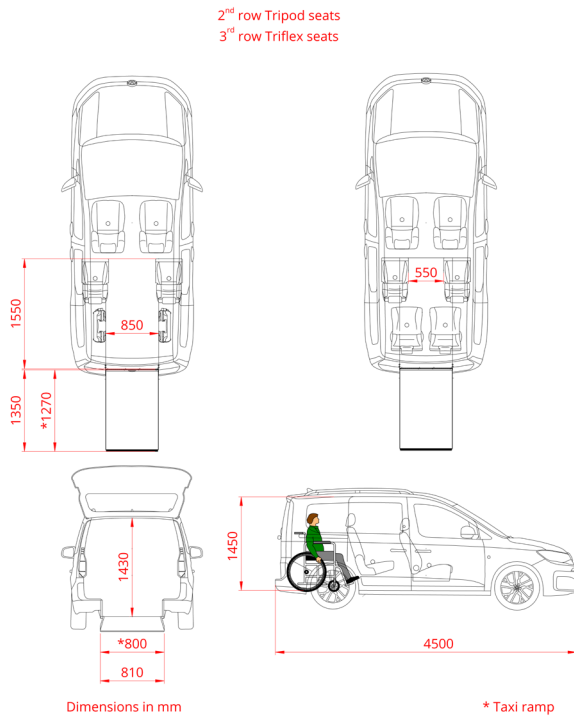

Seating options

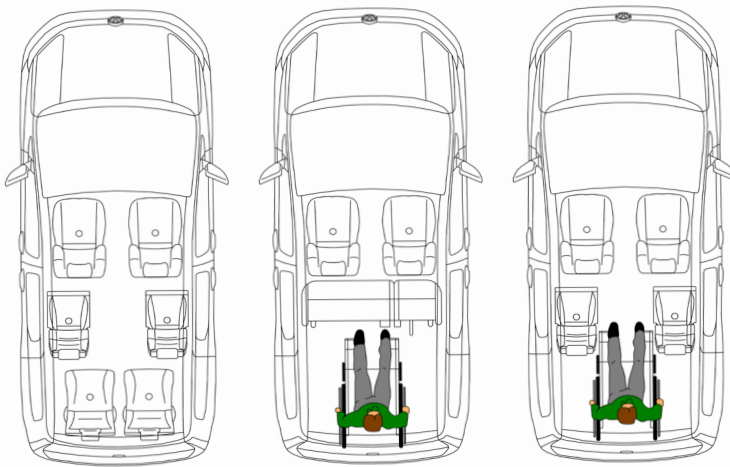

Standard conversion

- Lowered floor from rear up to front seats
- 4-point wheelchair tie-down system with an adjustable 3-point seatbelt for the wheelchair passenger
- New fuel tank and modified exhaust system to accommodate a deep and level lowered floor
- Double folding lightweight ramp allowing full view through the back window
- LED lights at ramp entrance for better visibility
- Lowered floor fully covered with matching upholstery
- The center part from the rear bumper will be replaced on the hatch, maintaining the original look

Options

- One or two (removable) Tripod seats on the second row
- or re-installing the original rear bench and seat with space for three
- One or two TriflexAIR foldable swivel seats on the third row
- Original parking sensors remain functional after conversion
- Foldable taxi ramp which creates a flat loading floor

Caddy Maxi 5 is the long version.
Carlength 4,85m.

Tested and approved by:



Measurements

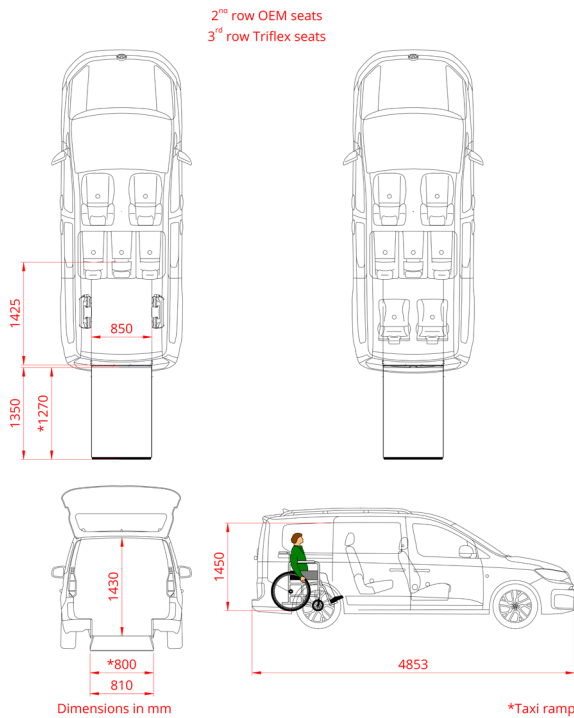

More pictures to follow soon....

Seating options

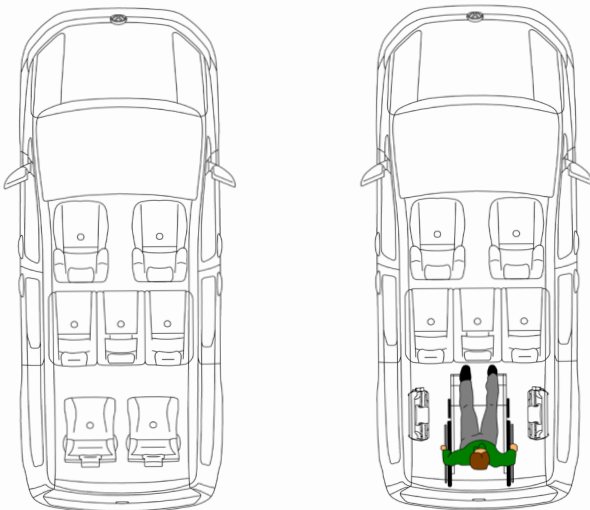

NOTE for both Caddy and Caddy Maxi 5

After launching the regular Caddy and Caddy Maxi 5, Volkswagen is bringing a SVO (special vehicle order) with altered rear axle that will be better equipped to make a lowered floor.

Standard conversion

- Lowered floor which extends up to second row
- 4-point wheelchair tie-down system with an adjustable 3-point seatbelt for the wheelchair passenger
- Modified exhaust system to accommodate a deep and level lowered floor
- Double folding lightweight ramp allowing full view through the back window
- LED lights at ramp entrance for better visibility
- Lowered floor fully covered with matching upholstery
- The center part from the rear bumper will be replaced on the hatch, thus maintaining the original look

Options

- One or two TriflexAIR foldable swivel seats on the third row
- Original parking sensors remain functional after conversion
- Foldable taxi ramp which creates a flat loading floor

Options

For each car there are many options available. Discuss these, or other options, with your dealer and order with your conversion.

Safety

Tripod Mobility values your safety above all. All our conversions have been developed with care and new conversions tested independently. The **European Type Approval** we provide, make for easy registration anywhere in the EU.

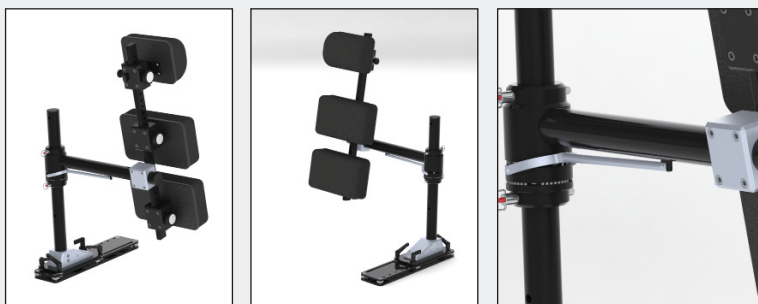

BodyGuard

Designed to offer the same protection to the wheelchair user a good car seat would

- back and neck support
- suitable for every car
- easily foldable
- safety tested

TriflexAIR seats

- One of the slimmest and lightest swivel seats available
- Comfortable because of their high quality filling and breathable upholstery
- Foldable and can be swiveled out of the way to make room for the wheelchair
- M1 Approved & tested according to the highest safety standards
- ISOFIX attachment points for child safety seats passenger



Taxi ramp

- Ramp that folds flat into the boot allowing for flexible use of the boot
- For wheelchair user when in vertical position
- Easy access to baggage when folded down, holds up to 80kg
- Clear rear view when folded down
- Tested according to regulation ECE-R11

Disclaimer; prices and descriptions are based on the information available during publication and are valid until further notice. We cannot guarantee the correctness and completeness of the information given and therefore do not accept liability.